



***The Name for  
Attenuators***

<b>ALAN MODEL 50CA2-10 PM PANEL MOUNT CONTINUOUSLY VARIABLE ATTENUATOR ELECTRICAL SPECIFICATIONS</b>	
<b>FREQUENCY RANGE</b>	<b>1-2 GHz</b>
<b>IMPEDANCE</b>	<b>50 Ohms</b>
<b>ATTENUATION RANGE</b>	<b>0-7 dB minimum</b>
<b>INSERTION LOSS</b>	<b>0.5 dB</b>
<b>MAXIMUM SWR</b>	<b>2.0:1</b>
<b>AVERAGE POWER</b>	<b>5 Watts</b>
<b>CONNECTORS</b>	<b>SMA Female</b>
<b>DRIVE</b>	<b>Screwdriver adjustment with locking nut</b>
<b>MOUNTING CONFIGURATION</b>	<b>Panel Mount</b>
<b>TEST DATA</b>	<b>Supplied at no charge when requested prior to shipment. Please allow extra 1-3 business days for shipping.</b>
<b>COUNTRY OF ORGIN</b>	<b>USA</b>
<b>RoHS STATUS</b>	<b>RoHS Compliant</b> <b>Available in a Non-RoHS configuration as a build to order product. Please contact factory to order.</b>

# **Alan**

***The Name for Attenuators***

**Alan Industries, Inc. • 745 Greenway Drive • Columbus, Indiana 47201 • USA  
800-423-5190 or 812-372-8869 • Fax: 812-372-5909  
www.alanindustries.com • sales@alanindustries.com**



**The Name for  
Attenuators**

## PHYSICAL DIMENSIONS

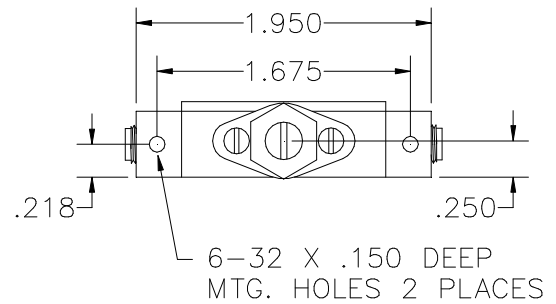
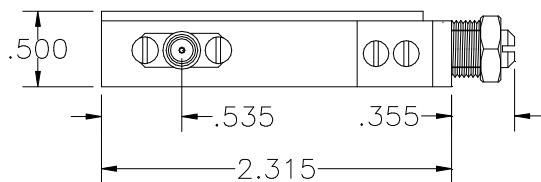
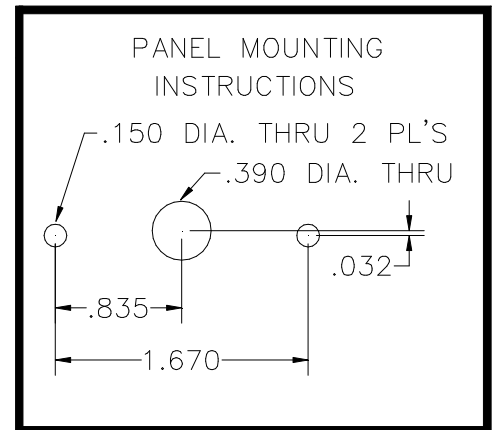
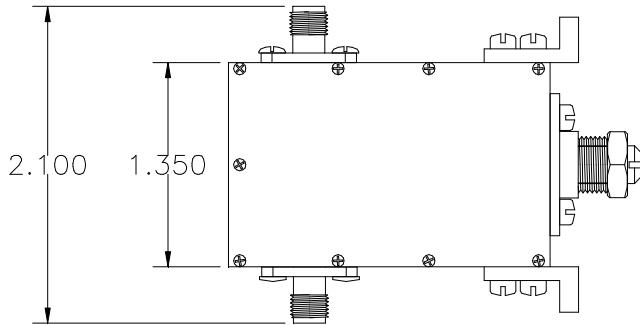

# Alan

**The Name for Attenuators**

Alan Industries, Inc. • 745 Greenway Drive • Columbus, Indiana 47201 • USA  
800-423-5190 or 812-372-8869 • Fax: 812-372-5909  
www.alanindustries.com • sales@alanindustries.com